

CORVUS UR Series

- Surface-mounted striplight ideal for wall washing or wall grazing
- For use with medium base PAR 20, PAR 30 or PAR 38 lamps up to 150W each. Lamps not included.
- Available in straight or flexible fixtures
- Constructed of heavy-gauge extruded aluminum with 120V medium base porcelain lampholders
- Available in 9" or 12" lamp spacing (Consult factory for custom spacing)
- Wiring and components are concealed inside housing for a sleek, finished look
- Available in mill finish and anodized satin
- Dimmable with standard line voltage incandescent dimmers
- Specify total length of single run; fixtures ship in segments to be mounted end-to-end to fill entire run length
- Fixtures are pre-wired for quick and easy installation (14 gauge wires)
- End caps include 7/8" diameter knockouts; conduit holes may also be opened on sides or bottom of fixture using drill bit
- Optional baffles available (finish to match fixture)
- ETL Listed for Dry and Damp location

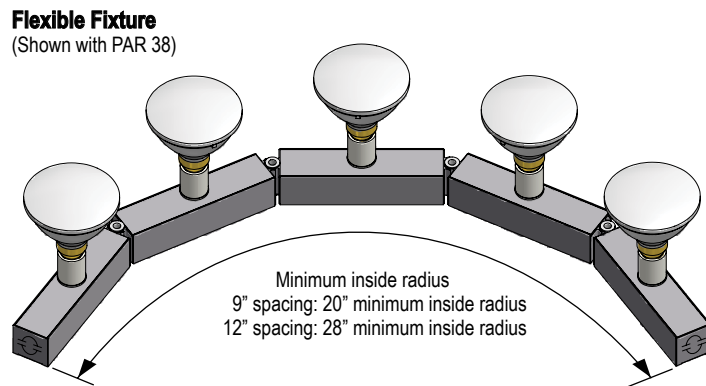

Optional Baffles

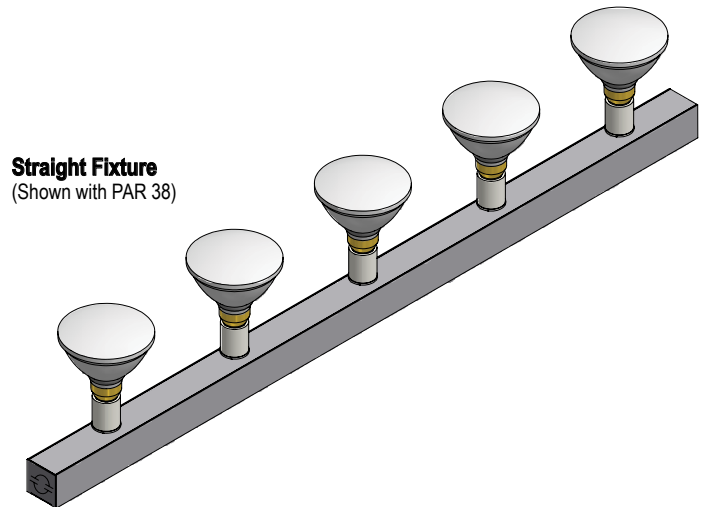
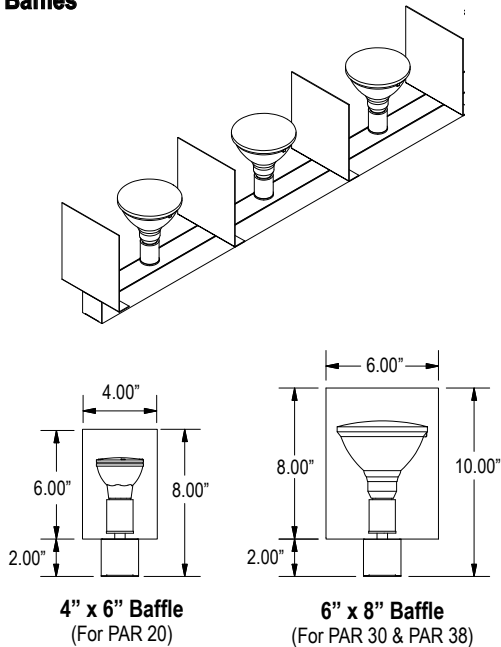

Recommended Lamps

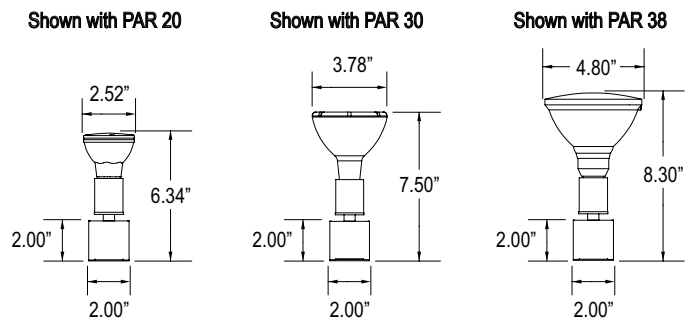

Only use medium base PAR 20, PAR 30 or PAR 38 lamps up to 150W each. Consult lamp manufacturer for details. Lamps not included with fixture.

How to Specify CORVUS UR Series

CRV - UR		-		-		-		
	Fixture Configuration		Lamp Spacing		Finish		Optional Baffle	
	ST	Straight fixture	9	9" on center	PST	Powder coat satin	B46	4" x 6" for PAR 20
	FL	Flexible fixture	12	12" on center	WHT	Powder coat white	B68	6" x 8" for PAR 30 & PAR 38
			Consult factory for custom spacing		BLK	Powder coat black	Baffle finish to match fixture finish Leave blank for no baffles	
Example								
CRV - UR	FL		12		PST			