

**Installation Instructions**

The following instructions are general guidelines. Installation should be performed by a qualified electrician in accordance with the National Electrical Code and any applicable local codes. Read through the entire instructions before beginning installation. Contact Celestial Lighting for further assistance.

**Step 1** Place template to desired location and mark holes. (Seat light should be mounted 12-18" above floor)

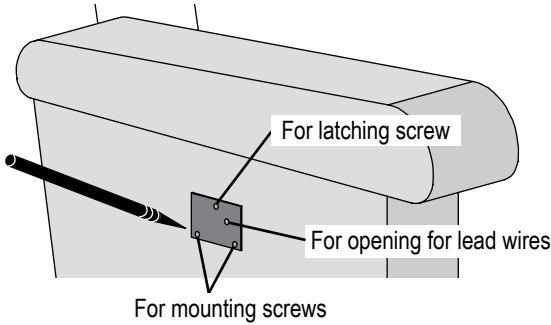

**Step 2** Create opening for lead wires. Opening should be approximately 7/8" diameter (approximately 22mm)

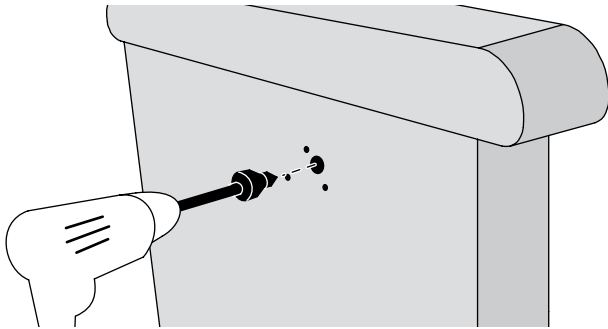

**Step 3** Drill top screw into seat panel. Leave approximately 1/16" gap (1.5mm)

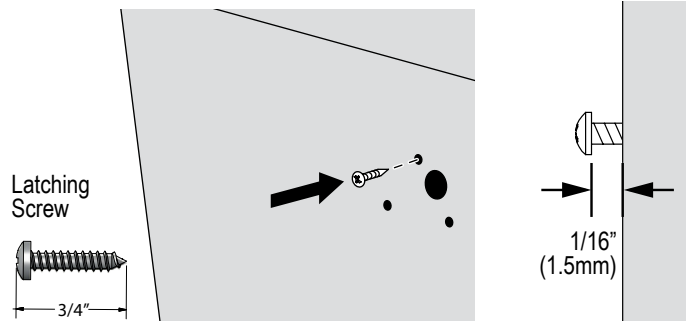

**Step 4** Feed lead wires from seat light into opening on seat panel.

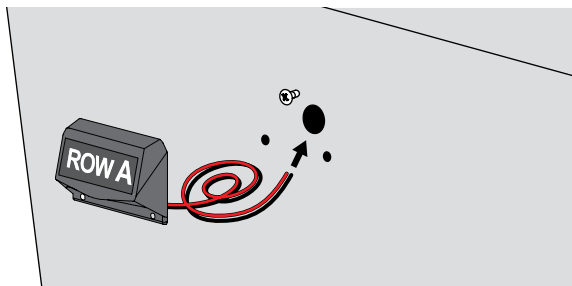

**Step 5** Hook seat light onto latching screw using latch on backside. Then, secure seat light to panel with two mounting screws.

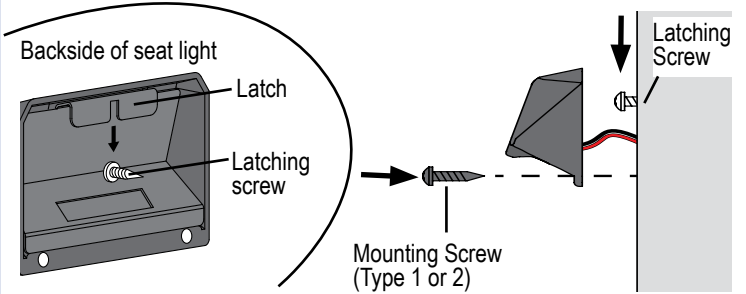

**Step 6** (For installations using GEMINI 5000 Stair Nose, End Cap and Raceway system)

Junction Box should be installed on step riser, between End Cap and Raceway. Wire Harness should be installed inside Raceway.

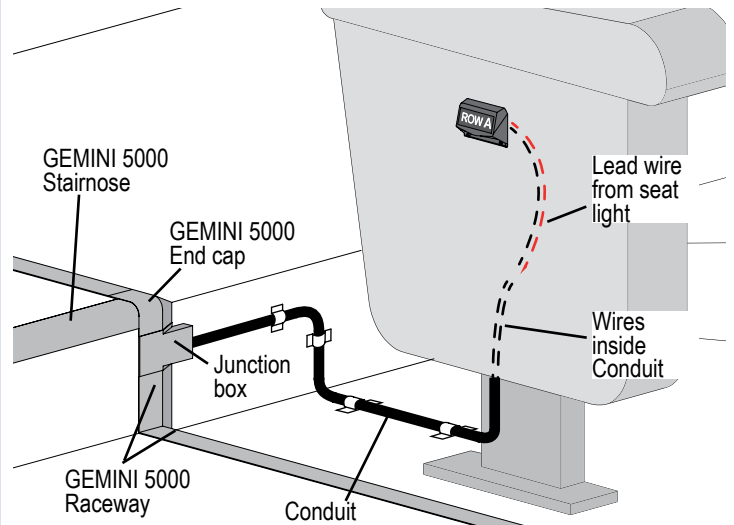

Install Conduit from Junction Box to seat, securing to floor as necessary with Conduit Clips. Within seat panel, connect lead wire from Seat Light to wires inside Conduit.

**Step 7** (For installations using GEMINI 5000 Stair Nose, End Cap and Raceway system)

Within Junction Box, connect wires inside Conduit to wire harness from Raceway.

